



## NOISE SUPPRESSION



### CUSTOM-ENGINEERED SOLUTIONS IN KNITTED WIRE MESH

For forty years, Metex design, development, and manufacturing engineers have been producing engineered components that take maximum advantage of the unique characteristics and robust nature of knitted wire mesh. Its interlocked looped structure, which offers excellent resiliency, memory—even when subjected to high temperatures as well as high-tensile or compressive stress—and strength, make knitted wire the ideal choice in materials when both performance and cost are paramount.

Metex products now meet a wide range of critical needs—from providing flexible, yet durable, seals and joints to noise attenuation, thermal insulation, and filtration—in some of the most demanding industrial applications and environments.

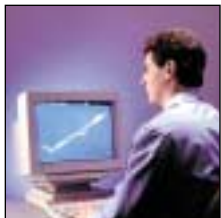

Complete in-house design, R&D, and test facilities



Flexibility in manufacturing for JIT requirements

## Reducing Acoustic Noise with Knitted Wire Mesh

Noise—whether continuous or intermittent—is unpleasant, reduces productivity, and may even promote hearing loss. In addition, meeting OSHA, MESA, and other state and federal legislative requirements mandates that manufacturers incorporate effective noise suppression in equipment.

Basically, there are four ways to achieve noise reduction:

- Add a physical sound barrier
- Install a vibration damper
- Provide sound absorption
- Metering the air flow

Only knitted wire mesh functions as all four—economically and as a single-composite material.

Due to its basic structure, knitted wire mesh provides exceptionally efficient absorption of high-energy sound. Beyond acting as a physical barrier, mesh also causes sound to vibrate as it imparts the wire surface, thereby converting sound to thermal energy, effectively dampening, absorbing, and dissipating equipment and plant-generated noise through an intricate path between a sound source and the ear.

In the same way that an aerator on a household faucet disperses the stream of water into smaller bubbles, so too, Metex knitted wire mesh distributes air—breaking it up and sending it through very small exit apertures before it is dispersed into the atmosphere. Metex knitted wire mesh combines all three approaches to sound attenuation in one composite structure: it acts as a reflecting barrier, a vibration damper, and a sound absorber. This three-in-one combination is cost effective and is easier to design with reduced space requirements. It can be incorporated into existing products without changing their design specifications and manufacturing.



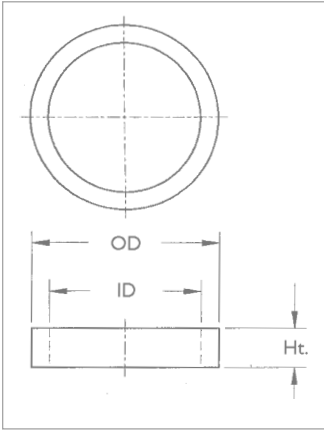

## PRODUCT BENEFITS

- ❑ Lightweight—especially as compared with metal baffling
- ❑ Easy to install
- ❑ Adaptable to a wide range of design configurations
- ❑ Resistant to high temperatures, cryogenics and corrosion
- ❑ Wide range of material selections
- ❑ Low pressure-drop to noise-reduction ratio
- ❑ Adaptable to a wide range of design configurations, including compressed units, wound units, and drawn and cal-endared.



Knitted metal sound-damping units can be produced in configurations to fit directly into new or existing designs

## More Efficient, Economical Noise Reduction for Equipment and Industrial Plants with Knitted Wire Mesh

Unlike metal baffle plates—which usually involve costly welded constructions and add significant weight—Metex knitted wire mesh noise-suppression solutions are light in weight and economical. Metal baffles can also slow the passage of air—in some cases resulting in reduced equipment operating efficiency due to generation of excessive back pressure. Porous materials such as foamed plastics and synthetic felts are highly susceptible to degradation at elevated temperatures—leading to eventual embrittlement and decomposition.

Knitted metals can be virtually custom tailored to specific needs of a given application. Engineered products can be fabricated from Metex by knitting one or a combination of widely diverse materials, such as all types of stainless steel, aluminum, copper, sophisticated alloys, synthetic polymers, fibers, and yarns.

In addition, knitted metal mesh has both a large surface area of wire to absorb sound vibrations, and a highly controllable percentage of free sound-deadening space. In fact, the open space in a mesh part can be controlled within a range of 30% to 97%. These two features are extremely important in noise reduction, since the extent of surface area and air flow resistance are both critical factors.

Knitted wire mesh has an ability to absorb high-energy sound. When this sound energy hits a knitted mesh element, the sound energy is absorbed into the wire structure, making the wire vibrate and thus absorbing harmful sound energy.

## Advantages

In compressed air tools where the escaping exhaust air creates sound levels in excess of ever-tightening government regulations, sound must be reduced, yet back pressure cannot significantly affect output power of the tools. Metex has developed several compressed knitted wire units for air tools. In a typical case, sound was reduced from 98 to 88 dB, with a loss of only 100 RPM out of 6000 in a hand-held, air-operated impact wrench.

Another example is the use of Metex knitted copper mesh in high-voltage circuit breakers. When these breakers are tripped, there is a deafening sound and electric arc. The inside of the enclosure is mesh lined to absorb this high-energy sound and arrest any flying sparks.

In control valves on pipelines where rushing vapors or gases create unwanted noise, knitted mesh is used as a packing which has many very small paths for instantaneous flow passage. As a sound wave passes by the materials, the pressure fluctuation causes instantaneous flow in and out of the passages. Acoustic energy is converted to heat by viscous friction. An advantage of knitted mesh here is its ability to resist degradation, and not come out of place during flow of the material in the line. With packed silencers, attenuation can be obtained up to 30 dB.

## Applications

The superior noise-suppression characteristics of Metex knitted wire mesh provide greater performance in a wide range of applications, including:

### ■ Silencers

- Air tools
- Compressors
- Air Motors and Starters
- Cylinders and Valves

### ■ Blankets and Curtains

- Machine or Equipment Isolation
- Internal Combustion Engines
- Mining

### ■ Mufflers

- Automotive
- Marine
- Recreation Vehicles
- Small Gasoline Engine-Powered Equipment

## Performance

Because of its multiple advantages, Metex knitted wire mesh, compressed and formed to required configurations, offers widespread applicability for sound deadening in many different product areas:

### ■ Hoist

- 30 dBA noise reduction: from 115 to 85 dBA.

### ■ Nailer

- 11 dBA noise reduction: from 111 to 100 dBA in equipment that fires 2 1/2" nails into soft wooden blocks. Process noise was reduced 4 dBA: from 93 to 88.9 dBA. Simultaneously, air exhaust noise was reduced 19 dBA: from 100 to 81 dBA.

### ■ Pneumatic Drill

- From 85 dBA to 80 dBA reduction at free run.

### ■ Handheld Pneumatic Saw

- A 10 dBA reduction: from 98 to 88 dBA, with an RPM loss of less than 2%.

### ■ Industrial Stapler

- 5 1/2 dBA noise reduction: from 105.5 to 100 dBA. Further reduction was limited by steel process noise level.
- In another application, process noise was unaffected. But the manufacturer achieved a 13 dBA reduction in air noise from 98 to 85 dBA.

### ■ Nut Driver

- 8 dBA reduction: from an unsatisfactory 85 dBA to a most desirable 77 dBA at free run.

### ■ Router

- A 19 dBA reduction: from 99 to 80 dBA.

Of equal importance to the dramatic noise level reduction achieved with Metex knitted wire mesh in these power tools is the important fact that not only were operating speed losses minimal, but the operating efficiency of the tools was not significantly reduced.

Most important of all from a product design standpoint, these results were obtained with little or no modification of the tools.



Noise-suppression solutions can be created from both metallic and non-metallic materials to meet specific requirements



Knitted construction permits the production of noise-suppression solutions in almost any material, density, thickness, or configuration



Materials such as copper—a lower-cost alternative to stainless steel—can also be knitted for noise suppression



## Metex Knitted Wire Mesh Products Solve Problems Cost Effectively

Metex knitted wire mesh is manufactured from an "endless" wire that is formed into loops and subsequently networked, providing elasticity and resilience not found with woven wire or powdered metal products.

The diversity and versatility of wire mesh enables Metex to produce products for a wide variety of applications, including:

- |                                       |                        |                        |
|---------------------------------------|------------------------|------------------------|
| • Seals                               | • Heat Wicks           | • Air Gap Rings        |
| • Breathers                           | • Noise Attenuators    | • Filters              |
| • Coalescers                          | • Mufflers             | • Shock Absorbers      |
| • Gaskets                             | • Air Filters          | • Protective Coverings |
| • Heat Shields                        | • Electronic Shielding | • Exhaust Seals        |
| • Navin Rings                         | • Ball Joint Seal      | • Catalytic Converter  |
| • Catalytic Converter<br>Support Mesh | • Systems              | • End Rings            |
|                                       |                        | • Flame Arrestors      |

Our **Knitted Wire Mesh Noise-Suppression Solutions** continue a longstanding Metex tradition of integrating the right designs, materials, and manufacturing methods to meet customer needs for optimal performance at lowest possible cost.

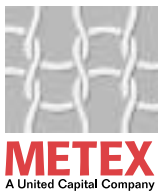

**Metex Corporation**  
970 New Durham Road  
Edison, New Jersey 08818  
Phone: 732-287-0800  
1-800-222-0969  
Fax: 732-287-8546  
E-mail: sales@metexcorp.com

**Metex Europe**  
4, Rue Pierre Brossolette  
92130 Issy Les Moulineaux  
France  
Phone: 33 (0)1 46 45 99 55  
Fax: 33 (0)1 46 45 99 07

**Metex Mexico**  
No. 30 Del Centro Industrial Limon Los Pinos  
En Av. Ferrocarril KM 14.5 En El Fracc. Los Pinos  
Tijuana, Baja California Mexico  
Phone: 011-52-66-89-74-34  
Fax: 011-52-66-89-74-53